



i M A R C

ENGRAVING SYSTEMS



PET TAG ENGRAVER USER MANUAL



2. Getting started
4. Holder Installation and Setup
6. Engraving a Tag
14. Engraving Clipart
15. Administrative Functions
16. International Characters
18. Clipart
20. Troubleshooting

Look for tips and tricks
on the inside back cover.

GETTING STARTED



Before you plug in the iMARC and engrave your first tag, familiarize yourself with some of the components of the machine.

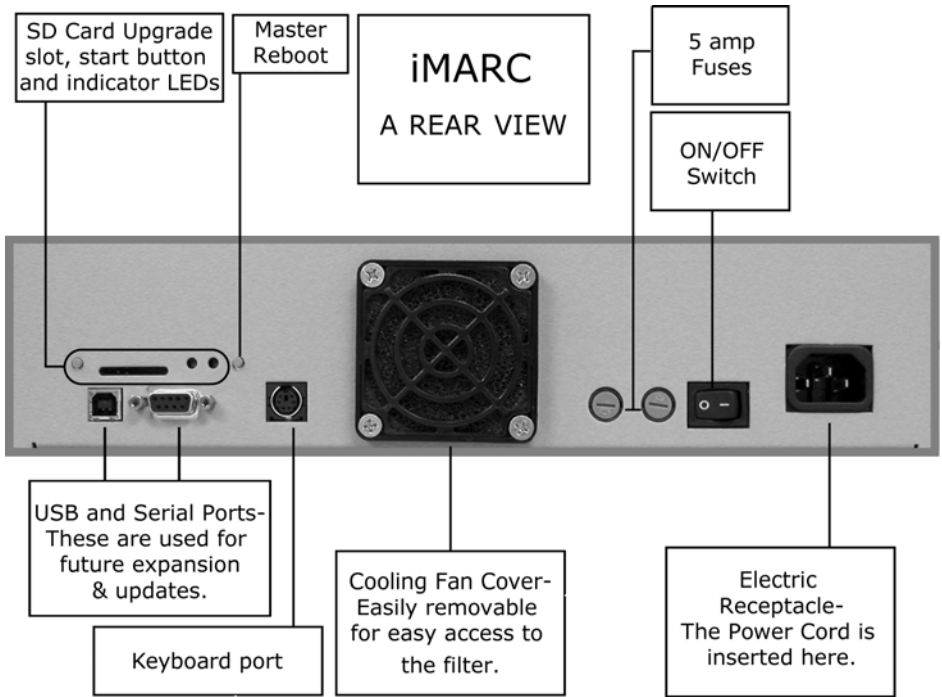



Setting up your iMARC is quick and easy.



Plug the keyboard into the keyboard port.



Plug your power cord into the electric receptacle.



Plug the cord into any standard (110 Volt) outlet,
and switch on the machine.

Note: If your machine is configured for 220 volts, there will a label (shown below) on the back side of your machine, near the electric receptacle.

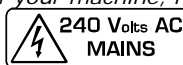

HOLDER INSTALL & SETUP



Once you've turned on your iMARC system, it is now time to install the holders. Your holders need to be installed on the engraving table during HOLDER SETUP.



*Engraving Table-
No holders installed*

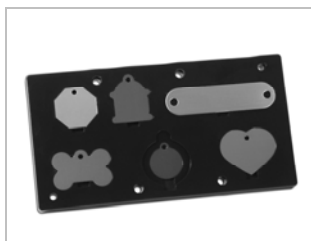

Tag Holder



*Engraving Table-
With holders installed*

Select the holders that you want to install –

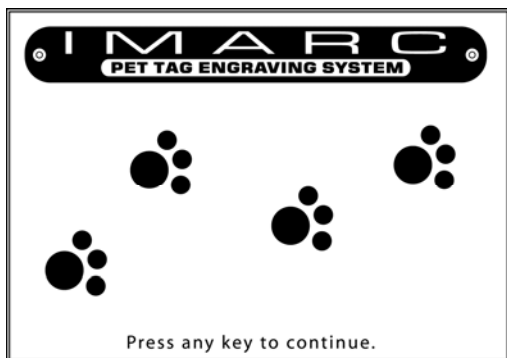

This is the first screen you will see. This is the INTRODUCTION SCREEN.

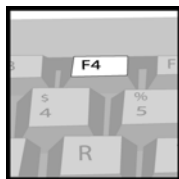

From the INTRODUCTION SCREEN, press F4 for holder setup.

Note: Holders can only be installed when you are in the HOLDER SETUP screen. Attempting to install them at any other time could result in damage to the holders or the machine.



HOLDER INSTALL & SETUP

The holder setup is simple. You can follow the onscreen instructions as well as the steps on this page.

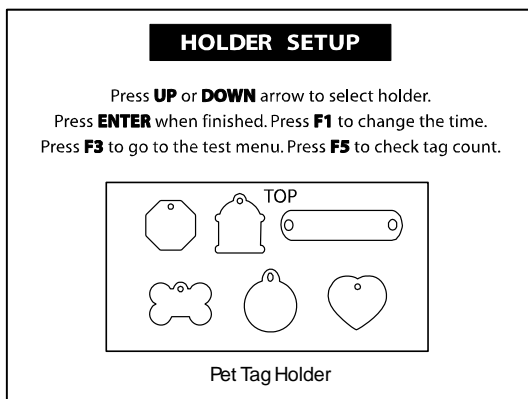

This is the HOLDER SETUP screen.

Insert your holder on the engraving table.

Note: For easiest installation and removal, position the holes in the holder directly over the pins in the engraving table, and move the holders directly up and down over the pins. It may be a snug fit, so apply light pressure as needed.

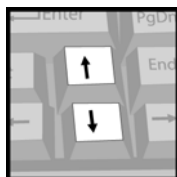

Press the up and down arrow keys to select the holder you've installed. Then press enter.

For instructions on setting the time, using the test menu, or checking your tag count, please turn to page 15.

ENGRAVING A TAG



Engraving a tag is quick and easy. Each option is clearly stated as you follow the steps to your completed tag.

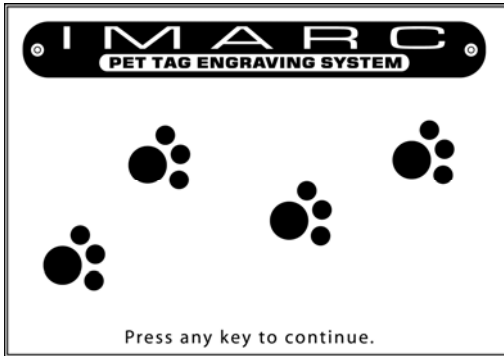

From the INTRODUCTION SCREEN,
press any key to get started.

*Note: After a period without
keystrokes, the machine will
reset to this screen.*



ENGRAVING A TAG

TAG SELECTION

Press **UP** or **DOWN** arrow to select the tag you want to engrave.

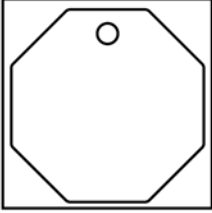

LARGE STOP SIGN

Press **F4** for holder setup.
To Continue press **ENTER** To go back press **ESC**

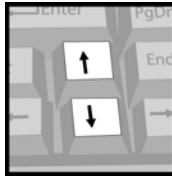

In the TAG SELECTION screen, move through the available tags using the up and down arrow keys.

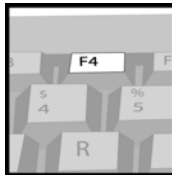

If the tag you want to engrave does not show up on the screen, press F4 to return to HOLDER SETUP and install the correct holder. (see pg. 5 for instructions)

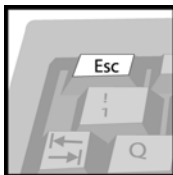

Press Escape to quit...

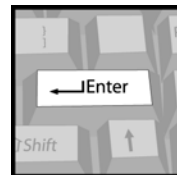

Press Enter to Continue...

ENGRAVING A TAG



After you've selected a tag,
choose the type style.

CHOOSE FONT
Select font to continue.

1. 1L Block	5. CONTEMPORARY
2. 2L Century	6. 3L ROMAN
3. 2L BLOCK	7. 5L Optima
4. <i>Script</i>	8. Clipart
	9. Your Logo (optional)

To go back press **ESC**

From the CHOOSE FONT screen, select the desired type style by simply pressing the corresponding number on the keyboard.

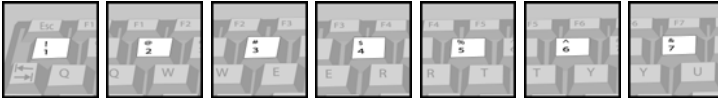

Hint: Pressing ENTER will select the iMARC BLOCK type style.

Press Esc to return to the TAG SELECTION screen.

CLIPART AND OPTIONAL LOGO FUNCTION-

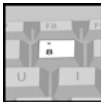

8 FOR CLIPART

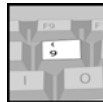

9 FOR YOUR LOGO

To engrave clipart onto your iMARC tags, press 8 and turn to page 14 for additional instructions.

If your iMARC has your company's logo stored in it, press 9 to select your logo and enter the letter A to engrave it.



ENGRAVING A TAG

Once you've selected a type style, it is time to type in the information to be engraved.

The diagram shows a rectangular screen with a large octagonal tag shape in the center. The tag contains the text: "Type information to be engraved." at the top, "Joe Black", "1345 E. Flint St", and "Phoeni" on the next line, and "LARGE STOP SIGN" at the bottom. To the right of the tag are four function keys: **ESC** CHANGE FONT, **F2** ENGRAVE TAG, **F8** CLEAR TEXT, and **F6** HELP SCREEN. Below these keys are the times "09:15:30" and "08/28/06". A small inset image shows a keyboard with the "Caps Lock" key highlighted. A note box on the right says: "Note: Caps Lock is on if CAPS shows in the top left of the iMARC screen."

Type in your information as you would like it to appear on the front of the tag. Keep in mind that iMARC will automatically increase or decrease your type size for optimum coverage. Press Enter once to go to the next line, twice to skip a line, or backspace to edit. Press F2 when the text is correct.

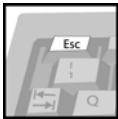

Press Esc to change your type style.



Press F6 to go to the help screen.

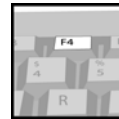

Press F4 to change your tag holder.

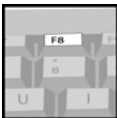

Press F8 to clear your information and start again.



Press F2 to insert your tag into the holder.

ENGRAVING A TAG



ENGRAVE TAG

You are about to engrave a
LARGE TOP SIGN
Ensure the correct tag is loaded in correct holder.
Press **F4** for holder set-up.
To Continue press **ENTER** To go back press **ESC**

TOP

Pet Tag Holder

The door will open and the table will move out for tag insertion. Insert the tag into the holder.

Note: Ensure that your tag is inserted completely flat into the tag holder.

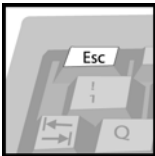

Press Esc at any time to go back to the TEXT ENTRY screen.

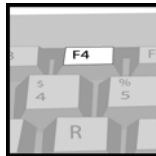

Press F4 to change your tag holder.

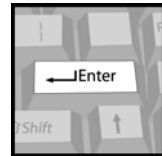

Press Enter to confirm your tag choice and placement, and proceed to the CHECK TEXT screen.



ENGRAVING A TAG

CHECK TEXT

Please ensure the text you have entered is correct.

Joe Black
1345 E. Flint St
Phoenix, Az

Font to be engraved is **Script 1L**

To engrave deeper press **2**. Press **F4** for holder setup.
To Continue press **ENTER** To go back press **ESC**

Using the CHECK TEXT screen, make sure you've typed in your information correctly and that you have chosen the correct type style.

Note: Text will not be enlarged to fit on the screen, but will be at the proper size on the tag.

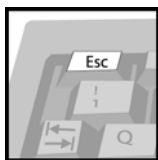

Press Esc at any time to go back to the text entry screen.

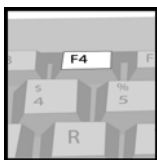

Press F4 to change your tag holder.

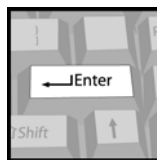

Press Enter to engrave your tag.



Pressing the number 2 will automatically engrave your tag twice, making the final engraving deeper.

ENGRAVING A TAG



The table will be pulled back into the iMARC and the door will close. While your tag is engraving, you will see the screen shown above.

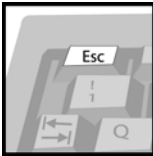

Press Esc at any time to stop the engraving process.

Note: Pressing ESC before iMARC starts to engrave will stop the machine before it engraves into the tag.



ENGRAVING A TAG

CONGRATULATIONS!

Your tag is finished!

- F1** — Engrave Other Side
- F2** — Engrave New Tag
- 1** — Repeat Previous Tag
- F4** — Holder Setup
- F8** — Edit Text
- ESC** — Return to Start Screen

When your tag is finished, the table will move out. When it stops, you can remove your tag, or flip it over to engrave the other side.



Once your tag is completed, press F1 to engrave the other side of your tag.

Note: This will bring you back to the CHOOSE FONT screen.



Press F2 to start a new tag.

Note: This will bring you back to the TAG SELECTION screen.



To repeat the same engraving on a new tag, press the number 1.

Note: The iMARC will automatically begin the engraving process.



Pressing the number 2 will repeat your last engraving, and will automatically engrave the tag twice, making the final engraving deeper.



Press Esc to return to the INTRODUCTION SCREEN.

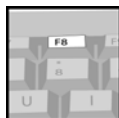

Press F8 to edit your text.
Note: This will bring you back to the TEXT ENTRY screen.



Press F4 to change your tag holder.



CHOOSE FONT
Select font to continue.

1. 1L Block	5. CONTEMPORARY
2. 2L Century	6. 3L ROMAN
3. 2L BLOCK	7. 5L Optima
4. Script	

8. Clipart 
9. Your Logo (optional)

To go back press **ESC**

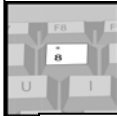

From the CHOOSE FONT screen, press the number 8.

Type information to be engraved.

Joe Black
1345 E. Flint St
Phoenix

ESC CHANGE FONT
F2 ENGRAVE TAG
F8 CLEAR TEXT
F6 HELP SCREEN
F4 HOLDER SETUP

09:15:30
08/28/06

LARGE 5 TOP SIGN



From the available clipart shown on pages 18 and 19, type the character representing the clipart you've chosen into the INPUT SCREEN, and then press F2.

Note: The character represents your clipart and will not be engraved.

CHECK TEXT
Please ensure the text you have entered is correct.

A

Font to be engraved is Your Logo

To engrave deeper press 2. Press **F4** for holder setup.
To Continue press **ENTER** To go back press **ESC**

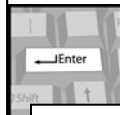

Press Enter to engrave the tag, or the number 2 for deeper engraving.

If you would like to add your company's logo to your iMARC, call 888-99-iMARC or email us at sales@imarcengraver.com



ADMINISTRATIVE FUNCTIONS

All of the functions that you and your managers might require can be found by accessing the holder setup screen.

(F4 from the introduction screen)

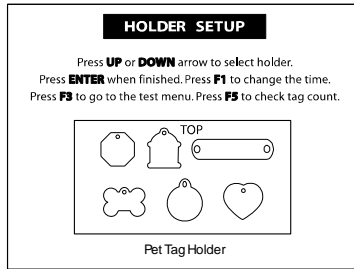

ADMINISTRATIVE FUNCTIONS



Setting the time is not needed; it will not affect your tags. However, should you wish, press F1, and then enter the correct local time.



TIME EDIT

Use the **TAB** key to change between time and date.

Press **ENTER** to save and exit,
Press **ESC** to exit without saving
Press **F4** to reset clock and RAM.

Time is 24 hour clock in HH:MM:SS.
Date is in MM/DD/YY format.

TIME:
DATE:

The iMARC contains an internal clock that will keep time even if it is unplugged.

All tests are done during assembly. However, we've provided access just in case. Press F3 to run tests.



TEST MENU

Please select the test you wish to do.

F1: Move test.
F2: Center point test.
F3: Leadscrew test,
ESC: Return to start screen.

Utilize the tag count screen to monitor your tag sales and track inventory.



TAG COUNT SCREEN

Your current tag output count is
000004

To go back press **ESC**



INTERNATIONAL CHARACTERS

Caps lock key on				
	Alt Key	Shift+Alt Key	Ctrl Key	Shift+Ctrl Key
A	À	â	Ä	á
E	È	ê	Ë	é
I	Ì	î	Ï	í
O	Ò	ô	Ö	ó
U	Ù	û	Ü	ú
Y				ý
N			Ñ	
C			Ç	
1	€	Ĝ	Ă	d'
2	£	Ş	Â	š
3		İ	Õ	ř
4		Ð	Æ	ž
5		þ	ß	
6			Ø	
7			ı	
8			ı	

Example: To get the letter è, you would need to have the caps lock key off, hold the alt key and press E.
 To get the letter Ñ, you would need to have the caps lock key on, hold the ctrl key and press N.
 To get the letter Æ, you would need to have the caps lock key on, hold the ctrl key and press 4.



Caps lock key off				
	Alt Key	Shift+Alt Key	Ctrl Key	Shift+Ctrl Key
A	à	Â	ä	Á
E	è	Ê	ë	É
I	ì	Î	ï	Í
O	ò	Ô	ö	Ó
U	ù	Û	ü	Ú
Y	ÿ	ÿ	ÿ	Ý
N	ñ	Ñ	ñ	
C	č	Č	ç	
1		ğ	ã	Ď
2		ş	å	Š
3		ı	õ	Ř
4		ö	æ	Ž
5		þ		
6	ě	Ě	ø	
7				
8				

Example:

To get the letter è, you would need to have the caps lock key off, hold the alt key and press E.

To get the letter Ñ, you would need to have the caps lock key on, hold the ctrl key and press N.

To get the letter Æ, you would need to have the caps lock key on, hold the ctrl key and press 4.

Instructions: To use the various clipart available in your iMARC, select the image you want, proceed through the tag selection screens as normal. In the **CHOOSE FONT** screen, press #8 then simply type the corresponding number or letter of your image in the **TEXT ENTRY** screen. Then press F2 and proceed as normal.

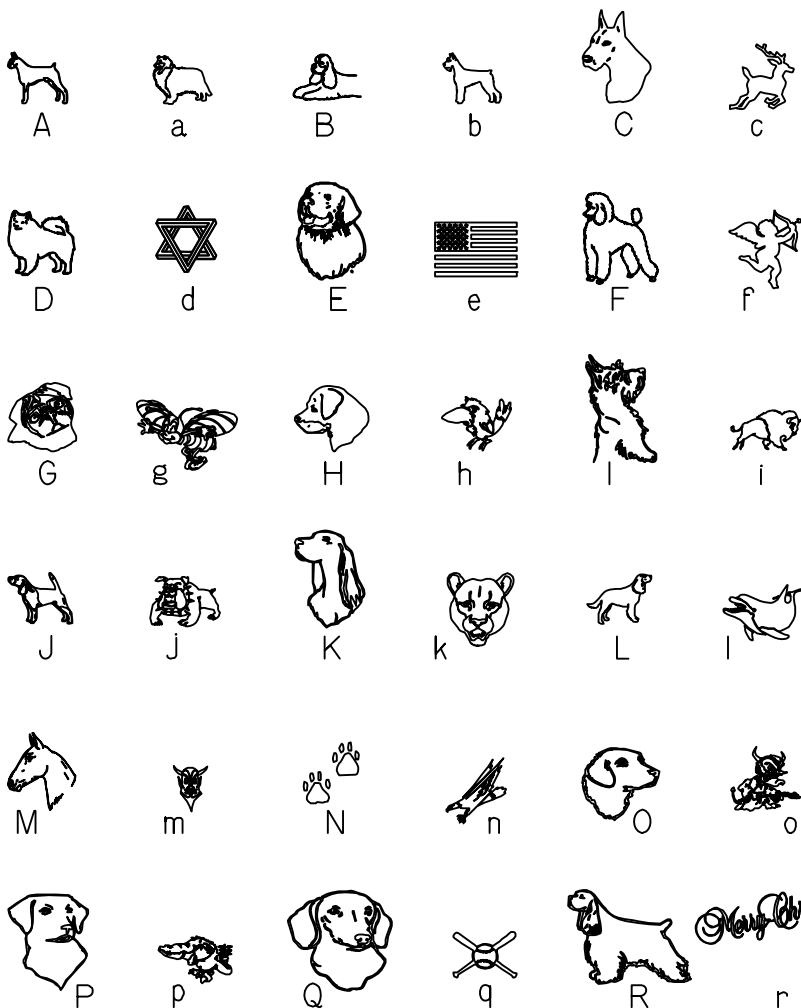

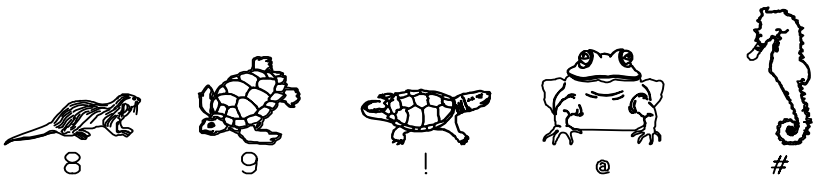
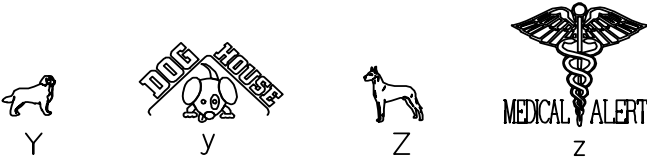
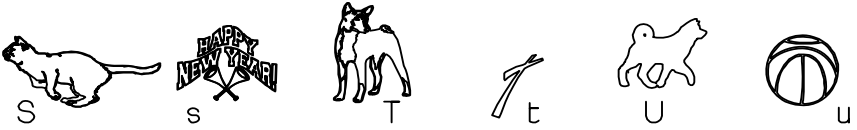



Adjusting the LCD contrast.



With your iMARC on, locate the LCD contrast wheel near the lower left front side of the machine. Using the tip of a pen (*Do NOT use a paper clip!*) apply *light* pressure to adjust the LCD contrast wheel inside the iMARC. Turn it left or right until the contrast is the way you like it.

Resetting the tag holders

Use this procedure if a large or small shape is missing on the iMARC screen when trying to engrave a tag.

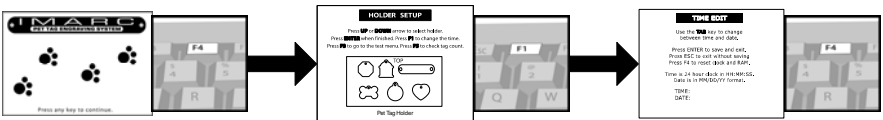

From the INTRODUCTION SCREEN, press F4 to go to the HOLDER SETUP screen. Then press F1 to go to the time edit screen. While in the TIME EDIT screen, press F4 to reset the machine. The time will change to zero. Reset the time and date as needed and press ENTER.

Press F4 again to set up your holders. (See page 4.)



i M A R C
ENGRAVING SYSTEMS

Technical Support
Sales

602-439-0700
602-439-8818

17621 N. Black Canyon Highway
Phoenix, Arizona 85023